

Technical Data Sheet



AirQon Synergies

F82 Hepa Box

Hepa Box is a terminal Device, which has no power relying on the Air Handling Unit to Supply or Exhaust air to achieve indoor air Circulations. The Ventilation Cycle is performed by indoor positive or negative pressure. The air from air handling unit, through Hepa box sent into cleanroom can be filtered, detoxified, sterilized and so on.

When the indoor pressure require is positive, the fan starts to send air from outside into duct and passes to Hepa terminal box. After filtering, clean fresh air is sent into the cleanroom, When the indoor pressure is higher than the outdoor pressure, The air is discharged from the air outlet and circulate in this way.

When indoor pressure is negative, the polluted indoor air will be discharged to outside through the exhaust outlet, forming a negative pressure inside cleanroom, allowing fresh outdoor air to enter the room through Hepa terminal box, so that the air in cleanroom reached cleanliness requirements.

Working Principles of Hepa Box

Interception Effect

When particles of a certain size move near the surface of the fiber, the distance from the centerline to the surface of the fiber is less than the particle radius, and the dust particles will be intercepted by the filter fiber and deposited.

Dust particles in the air usually move according to an inertial motion or unspecified Brownian motion along with the flow of airflow, or they may move due to a certain field force.

Therefore, when dust particles collide with other objects in motion, due to the existence of Van der Waals forces (the force between molecules and molecular clusters) between the objects, it is easy for the particles to stick to the surface of the fiber.

The dust particles entering the High efficiency particulate air filter have more chances to hit the medium due to the laminar airflow supply from the HEPA box, but they will be stuck as long as they hit the medium. When the smaller particle collides with each other, it will bond to each other, thereby forming larger particles and sinking down. The final particle concentration of the dust in the air will appear to be relatively stable.

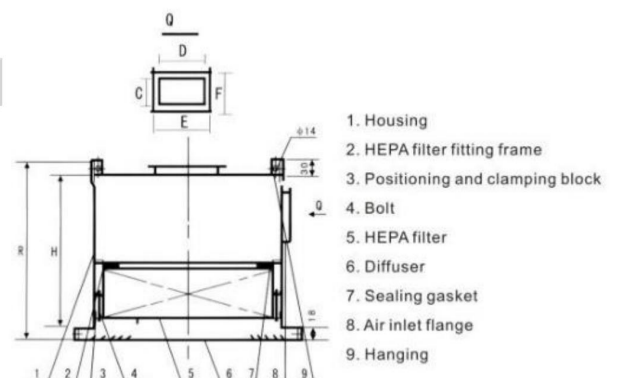

Technical Data Sheet



AirQon Synergies

Diffusion effect

The Brownian motion of particles with small particle size is stronger and easily collide with the fiber surface.

Particles move inertially in the air due to the flow of airflow, but when they collide with disorderly arranged filter fibers, the airflow changes direction and the particles deviate from the direction due to inertial action, causing them to collide with the fibers and be affected.

The larger the particles, the more easily they collide, and the better its effect. Small particles make irregular Brownian motion. The smaller the particle size, the more violent the particle is when it is in irregular motion, the greater the chance of it hitting obstacles, and the better the HEPA terminal box filtering effect.

The particles $<0.1\mu\text{m}$ in the air mainly subject to Brownian motion. The smaller the particle size, the better the terminal filtering effect. When the particle size is $>0.3\mu\text{m}$, the particle mainly performs inertial motion. The larger the particle size, the higher the terminal filtration efficiency.

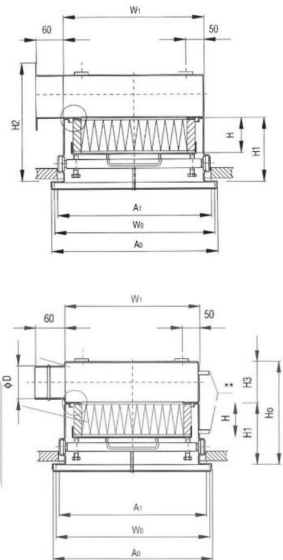

Inertial effect

When the particle mass or speed is large, the particle will be deposited on the surface of the fiber due to inertia.

Gravity effect

When particles pass through the fiber layer, they are deposited on the fiber due to gravity sedimentation.

Electrostatic effect

Fibers or particles may be charged, generating an electrostatic effect that attracts particles, and the particles are attracted to the surface of the fiber.

Construction

These Hepa Boxes can equip gasket type Hepa Filters.

The cabinet adopts the high-quality cold rolled steel / Galvanized Iron Sheet with powder coated or stainless steel.

Well-designed diffuser plate According to the principle of aerodynamics, designers carefully designed the diffuser plate to ensure that the air jet speed, to prevent the production of eddy current.

Air leakage test is more convenient, as HEPA box with DOP monitoring port and injection port can be tested after installed in time, it can check the leakage of gasket, frame and glass fiber media. It is more convenient and faster to test the leak detection of the sterile preparation workshop regularly. Widely used in different classes & various roof structures of non-uniform flow cleanroom.

Technical Data Sheet



AirQon Synergies

| Model Number | Filter Size | Housing Size | Damper Size |
|--------------|-----------------|-----------------|-------------|
| F821 | 305 x 305 x 150 | 370 x 370 x 305 | 250 x 100 |
| F822 | 305 x 305 x 292 | 370 x 370 x 381 | 250 x 150 |
| F823 | 457 x 457 x 150 | 520 x 520 x 305 | 400 x 150 |
| F824 | 457 x 457 x 292 | 520 x 520 x 381 | 400 x 150 |
| F825 | 610 x 610 x 150 | 673 x 673 x 305 | 500 x 150 |
| F826 | 610 x 610 x 292 | 673 x 673 x 381 | 500 x 150 |

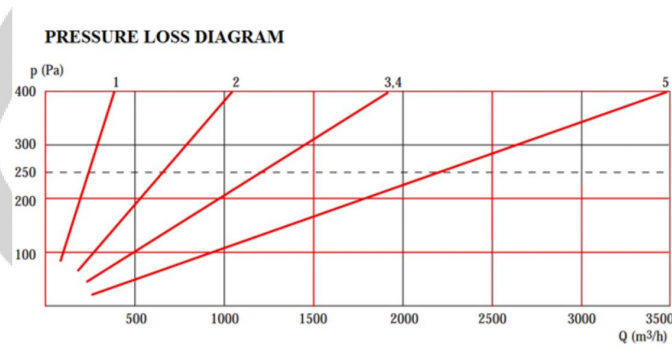

Pressure Loss Diagram